

# Elettropompe per sistemi anti-allagamento

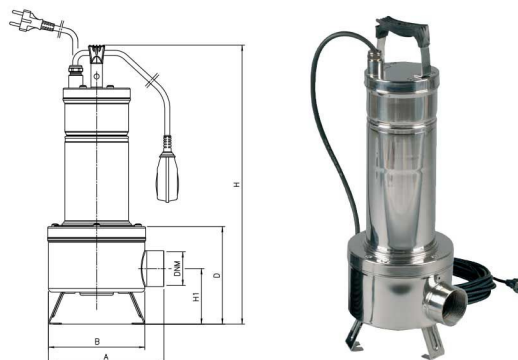

## VS 550 / VS 750 / VS 1000 / VS 1200

Elettropompa senza galleggiante - Girante arretrata - Cavo 10 mt. HØ7

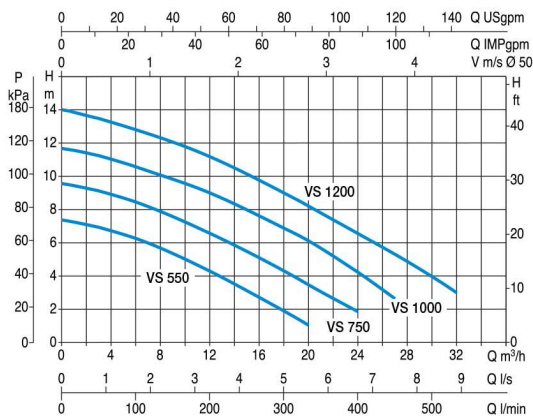

modello	A	B	D	H	H1	Ø DNM
VS 550	203	170	172	492	98	2"
VS 750	203	170	172	492	98	2"
VS 1000	203	170	172	537	98	2"
VS 1200	203	170	172	537	98	2"

CODICE	MODELLO	DATI ELETTRICI			DNM	PESO KG	DATI IDRAULICI							
		ALIMENTAZIONE 50 Hz	HP	A			H (metri)	7	6,5	6	5	4	3	1,8
90550	VS 550	1x230 V~	0,75	4,2	2"	16,3	H (metri)	7	6,5	6	5	4	3	1,8
							Lt./min	50	84	125	166	200	250	300
90750	VS 750	1x230 V~	1	5,13	2"	17,5	H (metri)	9	8,5	8	6,5	5,5	4,3	1,9
							Lt./min	75	100	125	200	250	300	400
90900	VS 1000	1x230 V~	1,36	6,63	2"	19,3	H (metri)	8	7,5	7	6,5	5,9	4,6	2,8
							Lt./min	100	150	200	250	300	400	500
91200	VS 1200	1x230 V~	1,6	8,63	2"	20,8	H (metri)	12	10	9	6,7	5	4	3
							Lt./min	150	250	300	400	460	500	550